

How to Measure the Water Level in a Well

(using an electric water level meter)



Oregon Water Resources Department
in collaboration with
Oregon State University Sea Grant Extension

June 2009

Definitions of Terms

Aquifer: A water-bearing layer of rock that will yield water in a usable quantity to a well or a spring.

Coaxial Water Level Meter: A water level meter used to measure the water level in a well through a coaxial wire (marked in color-coded increments) that emits a sound when water is detected.

Flat-Tape Water Level Meter: A water level meter used to measure the water level in a well through a flat tape (marked in engineering, standard, or metric scale) that emits a sound when water is detected.

Measuring Tube: A 3/4-inch PVC tube (see page 17) inserted into the well to help make collection of water level measurements easier and more accurate.

Recovering Water Level: A water level in a well that is recovering (rising) after the pump in the well has been turned off, but before the water level has stabilized.

Static Water Level: A stable water level in a well not affected by withdrawal (pumping) of ground water. This water level is most representative of surrounding aquifer conditions.

Water Table: The top of the water surface in the saturated part of an aquifer.

Water Well Report: A document containing important information about the construction of the well and the geology of the materials encountered during drilling. The well driller files this report with the state. A copy of the well report is available on the Oregon Water Resources Department (OWRD) website at www.wrd.state.us.

Well Cap or Sanitary Seal: A tight fitting, vermin-proof seal designed to prevent contaminants from flowing down inside the well casing.

Well Casing: A tubular structure made of metal or plastic and placed in a well borehole to maintain the well opening. The casing also helps to confine ground water to a specific ground water zone and helps to prevent contaminants from mixing with the water.

Well Liner: Often used in conjunction with a well casing, this metal or plastic insert is placed inside the well borehole to prevent a collapse.

Well Seal: This is a cement-like fluid injected into the well borehole to help protect the well casing.

Instructions for Measurement

These step-by-step instructions describe the equipment and methods needed to measure the water level in a well using both coaxial and flat-tape electric water level meters.

Measuring a water level in a well can sometimes be difficult. These instructions do not guarantee that you will be able to measure the water level in a well due to unique site conditions. Proceed cautiously if you choose to take a water level measurement in your well. There is always a potential that you could damage the well equipment or the water level meter.

COAXIAL WATER LEVEL METER

A coaxial water level meter uses a thin, round wire to transmit a signal to a buzzer when water is encountered. This type of meter is useful in wells where access to the borehole is narrow or, if a pump is installed, the potential of getting the meter tangled with obstructions exists. If this type of meter gets caught in the well, the weighted tip on the coaxial wire is designed to slide off to free the meter. Using the coaxial water level meter will save you the time and expense of having to remove the pump to retrieve the meter if it becomes stuck. **IMPORTANT:** if this type of meter becomes hung up, the meter should always be checked afterward to determine if the wire has stretched. Stretching affects the accuracy of future water level measurements.

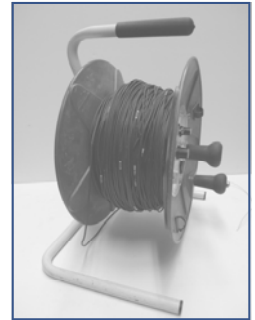

FLAT-TAPE WATER LEVEL METER

A flat-tape water level meter uses a flat “measuring tape” to transmit a signal to a buzzer when water is encountered. These tapes are usually 3/4-inch wide. The flat-tape water level meter is easier to read than a coaxial water level meter because the depth-to-water measurements are read directly off of the measuring tape. **IMPORTANT:** the flat-tape water level meter is only recommended for use in wells where a dedicated measuring tube is installed (see page 17) or if the well does not have a pump installed.



STEP ONE

Review information about the well and pump.

- **Water Well Report**

The well report (well log) contains important information such as the static water level when the well was constructed. A **static water level** is a stable water level when the well is not being pumped. The borehole construction section of the well report includes the depth of the well and information about the casing or the presence of a liner that could obstruct the water level meter from obtaining an accurate measurement. If you do not have a copy of the well report for your well(s), they are usually available on the OWRD website at www.wrd.state.us.

- **Well Identification (ID) Number**

The Well ID Number (well tag) is a unique identification number usually attached to the well casing by the well driller to wells constructed, deepened, converted, or altered after 1996. If your well does not have a well tag, a well tag application is available on the OWRD website at www.wrd.state.us. There is no cost to obtain a well tag. A well tag is necessary if you would like to submit your ground water level data to OWRD.

- **Pump Information**

Most domestic wells use a submersible pump either suspended from the casing wall or supported by the well cap. The depth that the pump is set is used to calculate the amount of water above the pump. The greater the depth of water above the pump, the more comfortable the well owner can be about the reliability of the water supply. Pump information may be found on receipts or other documentation provided by the pump installer.

TIP: The water level can be measured without the information discussed above. However, the person doing the measuring must be more careful because he or she will not have background information about the well.

STEP TWO

Turn off well pump and record the time.

Turn off the well pump for at least two hours before measuring the water level to ensure that conditions are static (non-pumping) in the well. In some cases, two hours will not be sufficient and the water level may still be rising in response to recent pumping. In other cases, it will not be possible to turn off the pump for two hours. The period of time the pump was off should be recorded on the data sheet. In all cases, care should be taken to document if the water level is static, rising, or falling at the time of measurement. A static water level is preferred as it best represents water conditions in the aquifer surrounding the well.

STEP THREE

Sanitize the equipment.

To sterilize the water level meter, fill a quart-size spray bottle with a weak chlorine solution. Mix one capful of chlorine bleach with water in a spray bottle (20:1 dilution with tap water). Be sure to only use household chlorine bleach which contains sodium hypochlorite (NaOCl) such as Clorox. Avoid other domestic bleaches with chemicals or fragrances that could contaminate your well.

CAUTION: use carefully as the solution will take the color out of clothing.

Spray the probe and line with enough solution to rinse off any visible dirt. Allow the water level meter to sit for about ten to fifteen minutes before the measurement. Be careful where you place the water level meter after you have sprayed it. The line or probe may pick-up bacteria from the ground near the well. If the line is extremely dirty, it should be rinsed with potable water and wiped with a clean cloth saturated in a weak chlorine solution. If you prefer, use a drop cloth or tarp to rinse the surface of the line clean before and after you measure the water level.



STEP FOUR

Determine well access port and measuring point.

There are three common types of well caps used for domestic wells. Directions for gaining access to each of the caps are described next.

IMPORTANT: if access to the water is not possible or difficult, please contact a pump installer for assistance.

The **measuring point** is a reference point on the well casing or cap from which all measurements are made. It may be helpful to draw a sketch of this measuring point on your water level data sheet and mark the measuring point with permanent marker. Future water level measurements should always be taken from the same spot.

Installing a measuring tube will make it easier to measure your water levels.



(Please see the measuring tube diagram on Page 17.)

1 Turtle Back well cap with access plug.

Access to measure the water level in this well is fairly easy. Place a pipe wrench on the plug in the cap and pull in a counterclockwise direction. If the plug is rusted tight, you may be able to loosen it by spraying the threads with WD-40 or tapping lightly on the handle of the pipe wrench with a hammer. Once the plug is loose, remove it and set it aside. Be sure to set the plug down in a clean place and spray it with a weak chlorine solution prior to returning it to the cap. The top of the hole in the cap is the measuring point. After the water level has been measured, be sure to put the plug back in the cap and tighten it.

IMPORTANT: if the plug cannot be removed, remove the entire cap as described in the next section.



2 Turtle Back well cap without access plug.

Access to measure the water level in this well requires removing the entire cap. Use a box wrench or a socket wrench on the bolt and a crescent wrench on the nut. Loosen each bolt before removing them. The well cap should lift off. If the cap is stuck, tap it gently with a hammer. Once the cap is off, be careful not to drop anything down the well and set the cap nearby where you will not step on it or contaminate it. Place the nuts and bolts in the cap. The top of the casing is the measuring point. **CAUTION:** to avoid electrical shock, do not touch any bare wires visible inside the well. After the measurement, put the cap back on the well, lining up the bolt holes and the power outlet. Replace the bolts and nuts by tightening them.



3 Sanitary Seal well cap with access plug.

There is a 1/2-inch threaded plug on the opposite side of the cap from where the power goes through the seal. Remove the plug using a crescent or box wrench. Set the plug on the well cap while you are measuring the water level. The top of the hole in the cap is the measuring point. Be sure to put the plug back in the cap and tighten it after you are done with your measurement.



STEP FIVE

Complete the water level measurement.

Before you lower the water level meter into the well, there are three problems that could occur during the measurement.

- **Liners**

If a liner is present in your well (see the diagram to the right), the water level meter must be inserted inside the liner to get a reliable water level measurement. **CAUTION:** false readings are common if the probe is inserted outside of the liner. If the water level meter is inserted outside of the liner, you may get a false reading with a shallower than expected water level depth. If you are outside the liner, the line and probe may be covered in grit or grime when you reel it up. **IMPORTANT:** liners are not always centered in the well or near the top of the casing. Check the well report or look inside the well to see if a liner is present.

- **Hang-Ups**

These may happen while lowering or raising the water level meter. Liners, pumps and wires, joints in the discharge pipe, and rough edges on the inside of the well may cause hang-ups. **IMPORTANT:** if you encounter any serious hang-ups, you should recalibrate your water level meter.

- **Cascading Water**

Water may enter the well above the static water level and drip or cascade down the borehole. The water falling down the borehole may cause the water level meter to give a false reading. Sometimes you may be able to hear if cascading water is present. Just put your ear to the top of the measuring port, use a long tube, or use a stethoscope to listen for water flowing down the borehole.

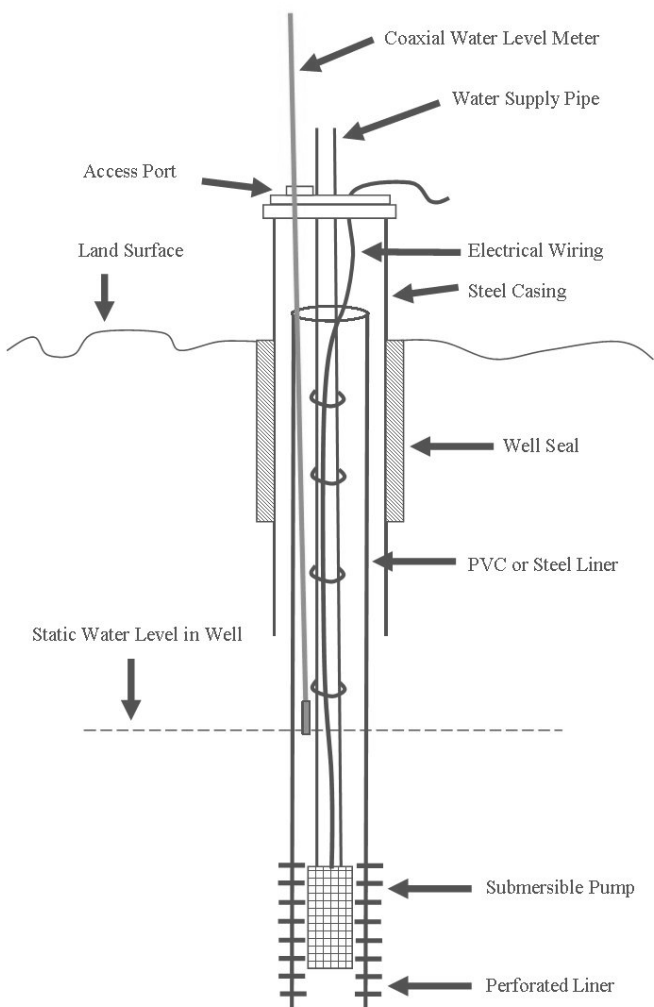

Above: Measuring water levels in wells with liners can be difficult. To get an accurate reading you must be sure that you are inside the liner. You also must be careful to avoid wiring or other potential hang-ups.

Before you lower the water level meter into the well, be sure that you know how to read the markings on the water level meter. The coaxial water level meter and the flat-tape water level meter have different measurement scales. **IMPORTANT:** until you become familiar with the marking code on the coaxial wire, it helps to count the marks as the line is slowly reeled into the well. Please follow specific instructions for your brand of water level meter.

COAXIAL WATER LEVEL METER

The coaxial water level meter has a thin line marked in five-foot increments. Determining how much line you have in the well requires counting the color-coded markers using a pattern similar to adding with Roman numerals. The color-codes for the markers on a Waterline (brand) water level meter are described below:

DEPTH (Feet)	COLOR-CODES FOR MARKERS
5	Pale Green/Orange/Pale Green
10	Pale Green
50	Orange
100	Green
500	Blue



FLAT-TAPE WATER LEVEL METER

The flat-tape water level meter usually has a 3/4-inch wide tape marked in engineering, standard, or metric scale. Determining how much tape you have in the well requires reading the tape (similar to reading a ruler).

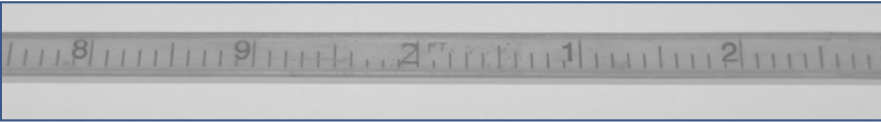

At this point, you have reviewed the information, sanitized the line and probe, and opened the access port. If you were able to locate the well report for your well, note the static water level. This will give you a target range for the water level. **IMPORTANT:** check the well report to see if an inner liner is present. If there is a liner, make sure the probe goes on the inside of the liner. Liners are occasionally installed after the well is constructed. In this case, the presence of a liner will not be documented on the well report.

Now you may begin to measure the water level.

1. Turn the lower switch to the test position and make sure the battery is good (the buzzer will sound and the light will turn on).
2. Turn the lower switch to either the BUZZ position or the LED position. The BUZZ position is recommended because you can hear the buzzer easier than you can see the light from the LED position.
3. Turn the sensitivity switch all the way to the right.
4. Slowly release some line down the well casing, allowing the line to slide over your outstretched hand and down the well.
CAUTION: do not let the line free fall because the line can give you a "burn" similar to a rope burn if it slides through your hand too fast or the line may get stuck in the well.
5. Check the "feel" of the line and probe. The "feel" of the weight on the line is similar to when you are fishing. You "feel" the line for the tug of a fish nibbling the bait. As the probe goes deeper, the weight should increase; if it does not, **STOP** lowering the line — go to Step 7.
6. Repeat steps 4 and 5 until the water level meter indicates the probe is in water or if the probe becomes stuck or hung-up. Remember to check the "feel" of the line and probe about every 20 feet.

7. If you can no longer feel the weight, raise the probe slowly. Continue checking the line to determine whether or not you have regained the weight of the probe. Once you can feel the weight again, begin lowering the probe very slowly. At the point when you cannot feel the weight, stop lowering the probe. Gently bounce the probe by raising and lowering the line about two feet. This method may allow the probe to slide past the hang up.
8. When the water level meter indicates water, check and make sure that you do not have cascading water. Determining if you have cascading water depends on the position of the lower switch. If the switch is set for BUZZ, the buzzer will chatter rather than sound a steady buzzing noise. If the switch is set for LED, the light will flicker off and on. Turn the sensitivity switch down to minimize the background noise.
9. Once you have determined that the probe is in the water, set the reel down while holding on to the line.
10. Raise the line until the light or buzzer goes off. Lower the line until the light or buzzer comes back on. Raise the line until the light or buzzer goes off, and hold the line in this position for 3 minutes to determine if the water is rising. At this time, you will know if your water level is rising, falling, or static. **IMPORTANT:** it is best to record a static water level. If the water level is still recovering (rising) from recent pumping of the well water, you have three options:
 - Wait another 5 to 10 minutes to take another measurement or continue measuring periodically until the water level is stable.
 - Come back another time to take a water level measurement.
 - Record the existing water level measurement on your data sheet and clearly indicate that the water level is rising.
11. After determining that you have a static water level measurement, use your other hand to pinch the line at the measuring point near the top of the well (which varies depending on the well cap).

12. Now you will need to determine the water level measurement at the measuring point. The two water level meters described in these instructions have different measurement scales and require different methods to determine the depth to water.

See **a)** below if you have a coaxial water level meter.

See **b)** below if you have a flat-tape water level meter.

a) Coaxial Water Level Meter

While continuing to pinch the line with your fingers, slowly pull the line out of the well until the nearest marker is visible. Take the pocket tape and measure the distance between the spot where you are holding the line and the bottom of the closest color-coded markers on the line below your hand. This distance is known as the CUT. Record the CUT on your water level data sheet. Next, note the value of the color-coded marker that you measured to just below the top of the casing. This distance is known as the HOLD. Record the HOLD on your water level data sheet. The CUT and the HOLD added together equal the depth to water below the measuring point.

OR

b) Flat-Tape Water Level Meter

Pull up the tape where you have grabbed the line to indicate the water level measurement. Record the number that is just under your finger at this location near the measuring point.

13. You should repeat Steps 10 through 12 again until you get a consistent measurement (indicating a stable water level).
14. Pick up the reel in your hand. Begin rewinding the line onto the reel. Rewind slowly and allow the line to move back and forth across the reel.
15. When the line and probe are out of the well, turn off the water level meter. Replace the access plug or the top of the well cap. Sanitize the water level meter and put it away.
16. Next, use the pocket tape to find the height of the measuring point (MP) above or below ground surface. Record the MP measurement on your data sheet.

17. Now, you need to calculate the depth of water below land surface using the data you have collected. The two water level meters described in these instructions have different methods to record this information.

See **a)** below if you have a coaxial water level meter.

See **b)** below if you have a flat-tape water level meter.

a) Coaxial Water Level Meter

The CUT is the length of line above the color-coded markers measured with the pocket tape. It is a positive number and should be added to the HOLD as shown on the following page.

If the MP is above land surface, the height of the MP is subtracted to convert the water level to feet below land surface (EXAMPLE 1). If the MP is below land surface, the MP should be added to convert the water level to feet below land surface (EXAMPLE 2).

OR

b) Flat-Tape Water Level Meter

Pull up the tape where you have grabbed the line to indicate the water level measurement at the MP. Record the number that is just under your finger at this location near the MP.

If the MP is above land surface, the height of the MP is subtracted to convert the water level to feet below land surface (EXAMPLE 1). If the MP is below land surface, the MP should be added to convert the water level to feet below land surface (EXAMPLE 2).

18. You are now finished taking the water level measurement for your well. Record this information, along with any important comments, on the data sheet and retain it for your personal records.

EXAMPLE 1 – Measuring Point Above Land Surface

COAXIAL METER

HOLD	270.00
CUT	+ <u>.31</u>
Water Level Below MP:	270.31
MP Correction:	- <u>1.00</u>
Water Level BLS:	269.31

FLAT-TAPE METER

Water Level Below MP:	270.31
MP Correction:	- <u>1.00</u>
Water Level BLS:	269.31

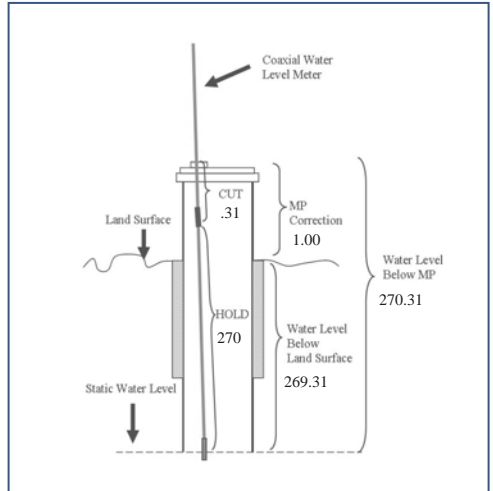

EXAMPLE 2 – Measuring Point Below Land Surface*

COAXIAL METER

HOLD	150.00
CUT	+ <u>1.00</u>
Water Level Below MP:	151.00
MP Correction:	+ <u>2.00</u>
Water Level BLS:	153.00

FLAT-TAPE METER

Water Level Below MP:	151.00
MP Correction:	+ <u>2.00</u>
Water Level BLS:	153.00

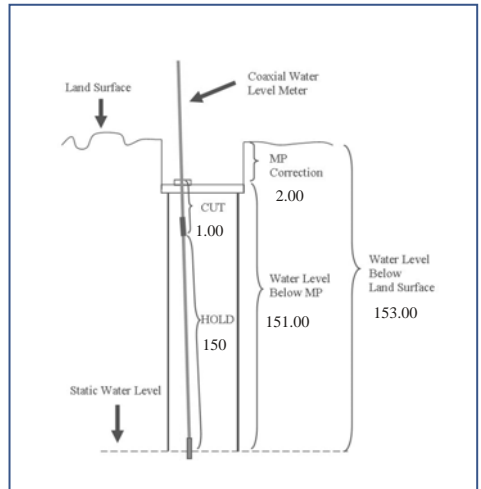

*To prevent surface water from contaminating your well, all well casing should rise at least 12-inches above land surface according to Oregon Well Standards.

STEP SIX

Interpret your water level measurements.

The easiest way to interpret ground water levels is to plot the data versus time. This type of figure is known as a **hydrograph**. You can compare the water levels in your well after you have recorded enough measurements over a period of time. **IMPORTANT:** before plotting the data, make sure that there are no math errors. Data errors can lead to a wrong interpretation of the data. Be sure to only compare static (non-pumping) water levels.

The example hydrograph shown on the top of the next page has higher water levels in the winter and lower water levels in the summer. This is a typical seasonal pattern that reflects higher recharge rates and less pumping in the winter versus lower recharge rates and more pumping in the summer. Water levels can be influenced by tides, changes in the weather, or nearby wells. In this example, water levels appear stable from one year to the next, with normal seasonal variations. **Note:** there was a drought during the year of 2001.

The example hydrograph shown on the bottom of the next page seems to have a steady decline of water levels from one year to the next. This could indicate a decline in the aquifer water levels in the general vicinity.

STEP SEVEN

Submit your water level measurements (optional).

OWRD has developed an online database for community ground water level measurements. This database will assist in providing more information about aquifer conditions in various parts of the state. If you are interested in submitting your ground water level measurements to the online database at OWRD, please contact a representative from the Ground Water section at 503-986-0900. Or visit the OWRD website at www.wrd.state.or.us and look for the Ground Water link for more information.

Normal Seasonal Fluctuations

Well Location
 Oregon
 State Observation Well Number
 7.00S3.00M188AD
 POLK 1781
 Elevation in feet above mean sea level
 323
 592
 UNUSED

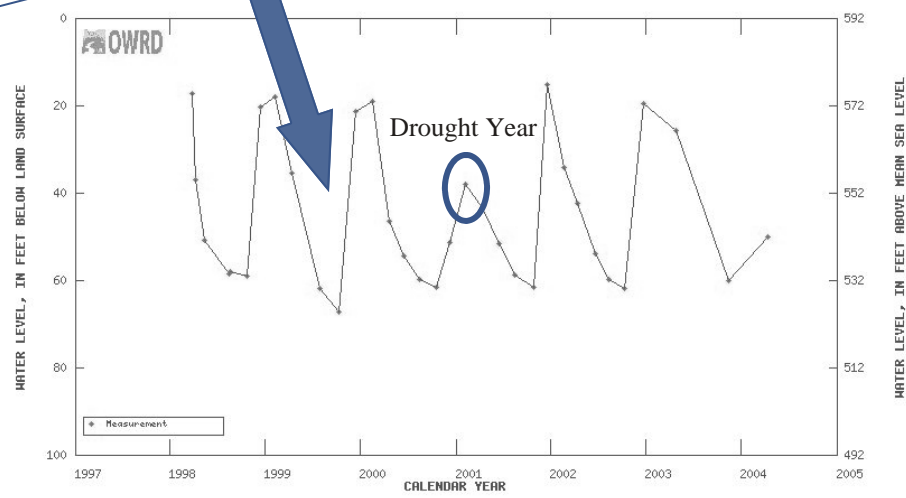

Possible Water Level Decline

Well Location
 Oregon
 State Observation Well Number
 3.00N30.00E22CCA
 UMAT 1364
 Elevation in feet above mean sea level
 965
 1130
 IRRIGATION

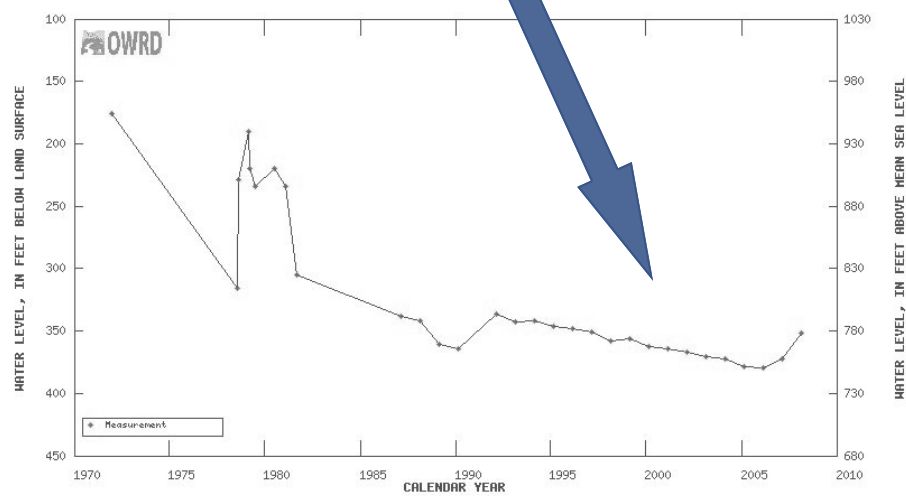

A MEASURING TUBE

A measuring tube in your well will make collecting ground water level measurements easier by preventing hang-ups. A measuring tube is a slotted 3/4-inch PVC pipe installed in your well used to measure the ground water levels. Some areas in Oregon require these tubes to be installed in wells at the time of pump placement. Go to http://www1.wrd.state.or.us/pdfs/DIV_20200.pdf for a description of areas and aquifers that require such installations in wells. Contact a local pump installer if you would like to have a dedicated measuring tube installed in your well.

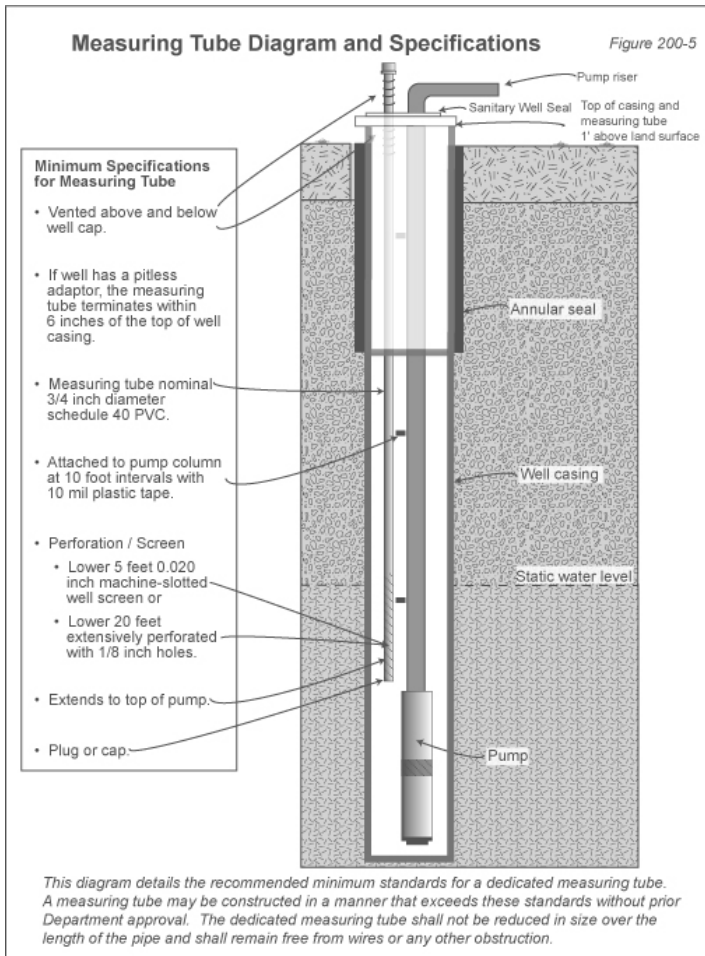

For More Information

This guidance document was adapted from a technical paper, **How to Measure the Ground Water Level in a Domestic Well Using an Electric Water Level Indicator**, by Marc A. Norton, hydrogeologist with Oregon Water Resources Department.

Other ground water level measurement publications include:

Quality-Assurance Plan for Ground Water Activities

Drost, B.W., 2005, U.S. Geological Survey, Washington Water Science Center: U.S. Geological Survey Open-File Report 2005 - 1126.

Ground Water Level Monitoring and the Importance of Long Term Water Level Data Collection

Taylor, C.J. and Alley, W.M., 2001, Denver, Colorado, U.S. Geological Survey Circular 1217.

Measuring Well Water Levels

Trimmer, W.L., 2000, Oregon State University Extension Service, EC 1368.

Other ground water educational websites include:

American Groundwater Trust

<http://www.agwt.org>

The Groundwater Foundation

<http://www.groundwater.org>

National Ground Water Association

<http://www.ngwa.org>

OSU Extension Well Water Program

<http://wellwater.oregonstate.edu>



State of Oregon
Water Resources Department
725 Summer St NE, Suite A
Salem, OR 97301-1266
503-986-0900
www.wrd.state.or.us



Sea Grant Extension
Oregon State University
307 Ballard Hall
Corvallis OR 97331-3604
541-737-8692
seagrant.oregonstate.edu/extension